



清華大學

Tsinghua University

Robust Anomaly Detection for Multivariate Time Series through Stochastic Recurrent Neural Network

Ya Su, Youjian Zhao, Chenhao Niu,

Rong Liu, Wei Sun, Dan Pei

SIGKDD 2019

Outline



Background



Algorithm



Evaluation



Conclusion

Outline



Background



Algorithm



Evaluation



Conclusion

Anomaly Detection

- Graph [SIGKDD 2018, AI Magazine 2014]
- Log Messages [SIGKDD 2016, SIGKDD 2017]
- Time Series [SIGKDD 2015, SIGKDD 2017, SIGKDD 2018] 

Entities with monitored multivariate time series

Entities



Server Machine

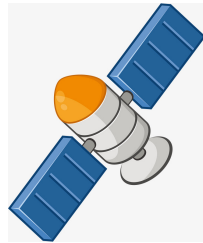

SpaceCraft



Robot-assisted
System

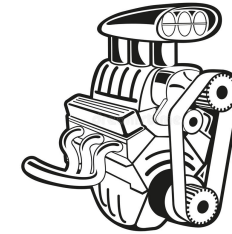

Engine

...



Multi-metrics

CPU Load
Network Usage
Memory Usage
...

Radiation
Temperature
Power
...

Kinematic
Visual
Haptic
...

Accelerator
Torque
Temperature
...

...

Entities with monitored multivariate time series

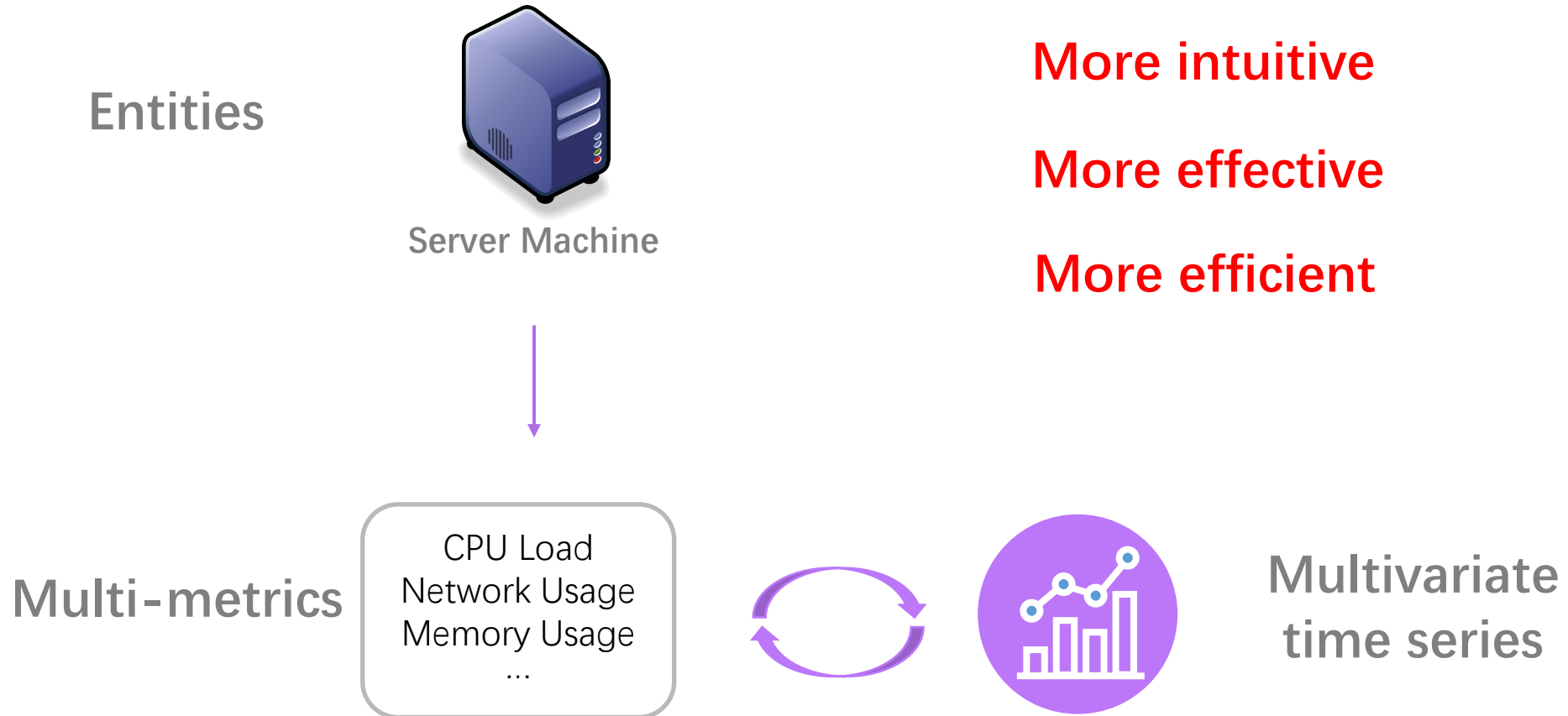

Machine with monitored multivariate time series

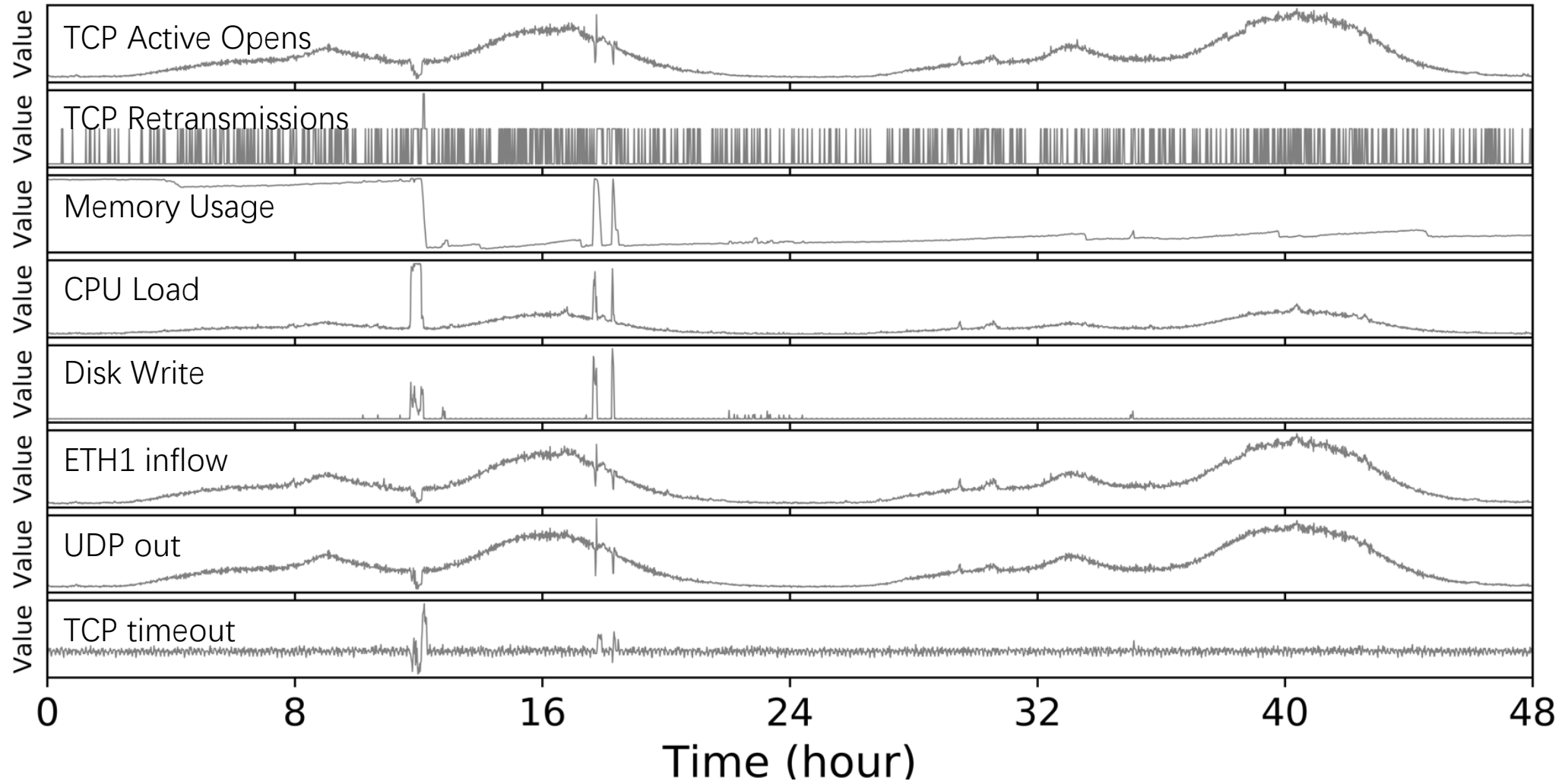

Machine with monitored multivariate time series

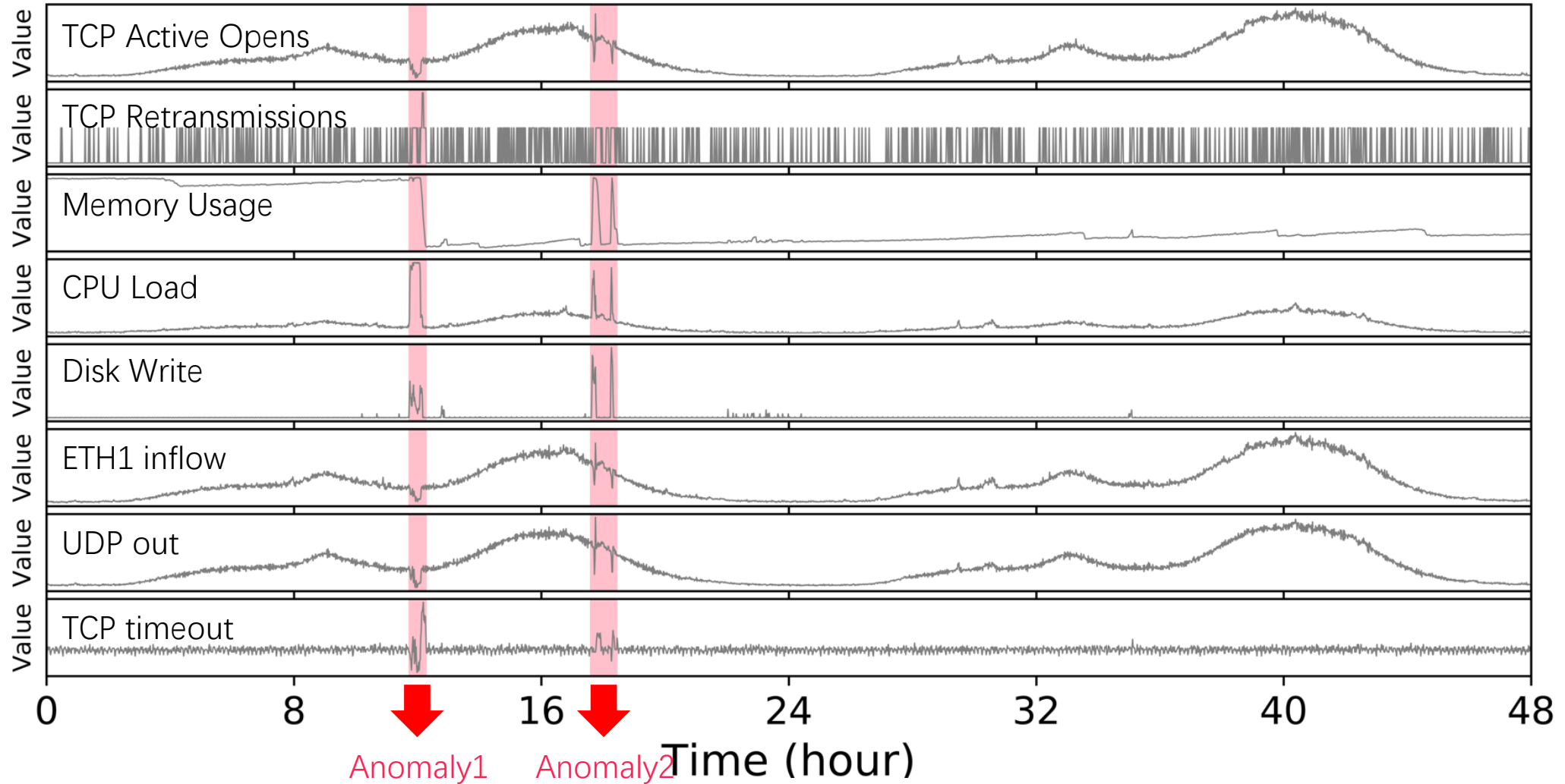

Motivations

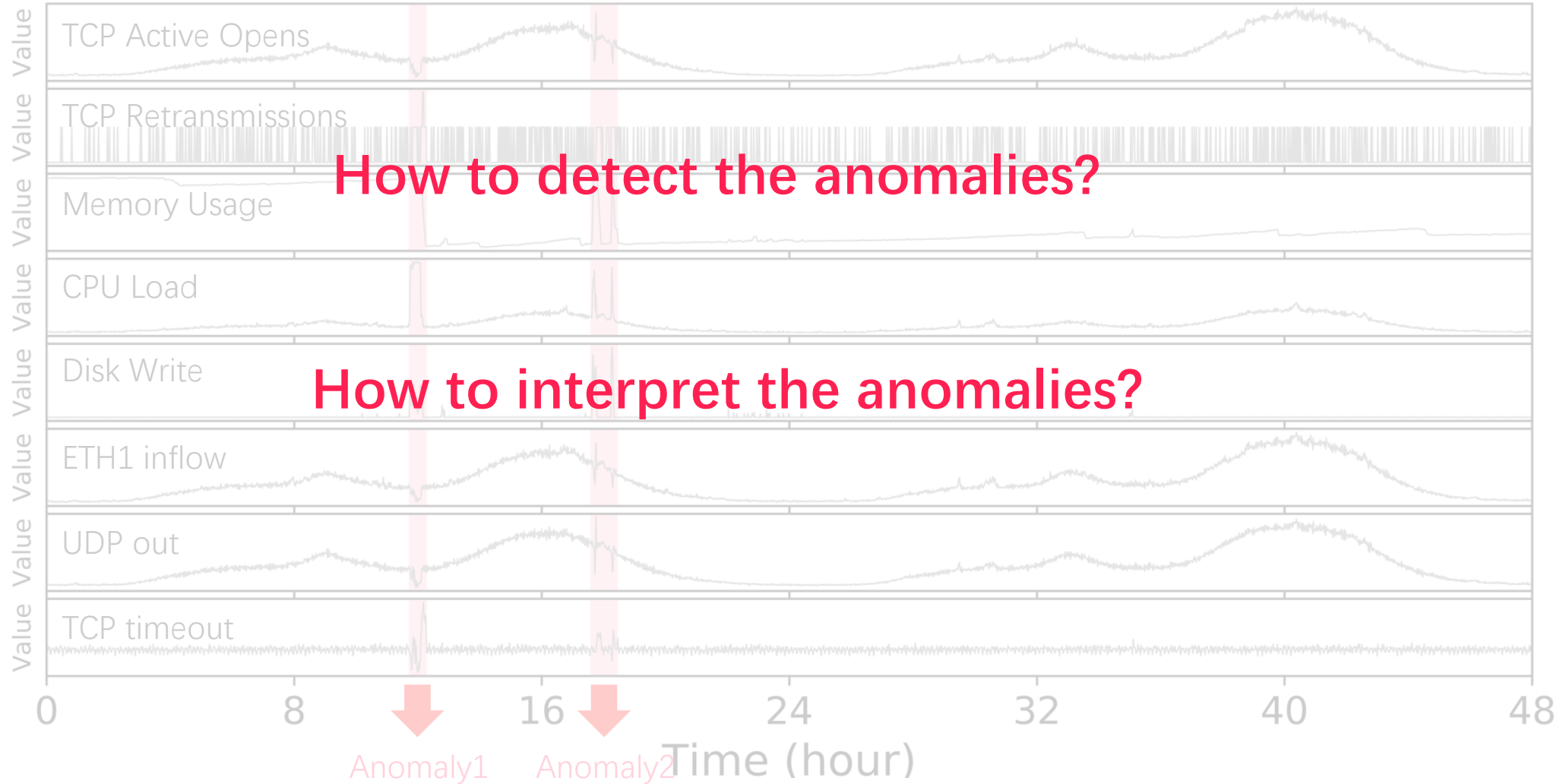

Challenges

- How to deal with the temporal dependence of multivariate time series ?
- How to deal with the stochasticity of multivariate time series ?
- How to provide interpretation to the detected entity-level anomalies ?

Related work

Deterministic models	Stochastic based models
LSTM、 LSTM-based Encoder-Decoder [SIGKDD2018, ICML workshop 2016, NIPS 2016]	DAGMM、 LSTM-VAE [IEEE Robotics and Automation Letters 2018, ICLR 2018]
Deterministic models without stochastic variables	Ignore the dependence of time series or stochastic variables.

Outline



Background

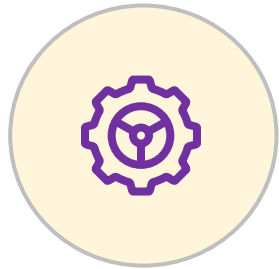

Algorithm



Evaluation



Conclusion

OmniAnomaly

Helps answer the questions

Structure of OmniAnomaly

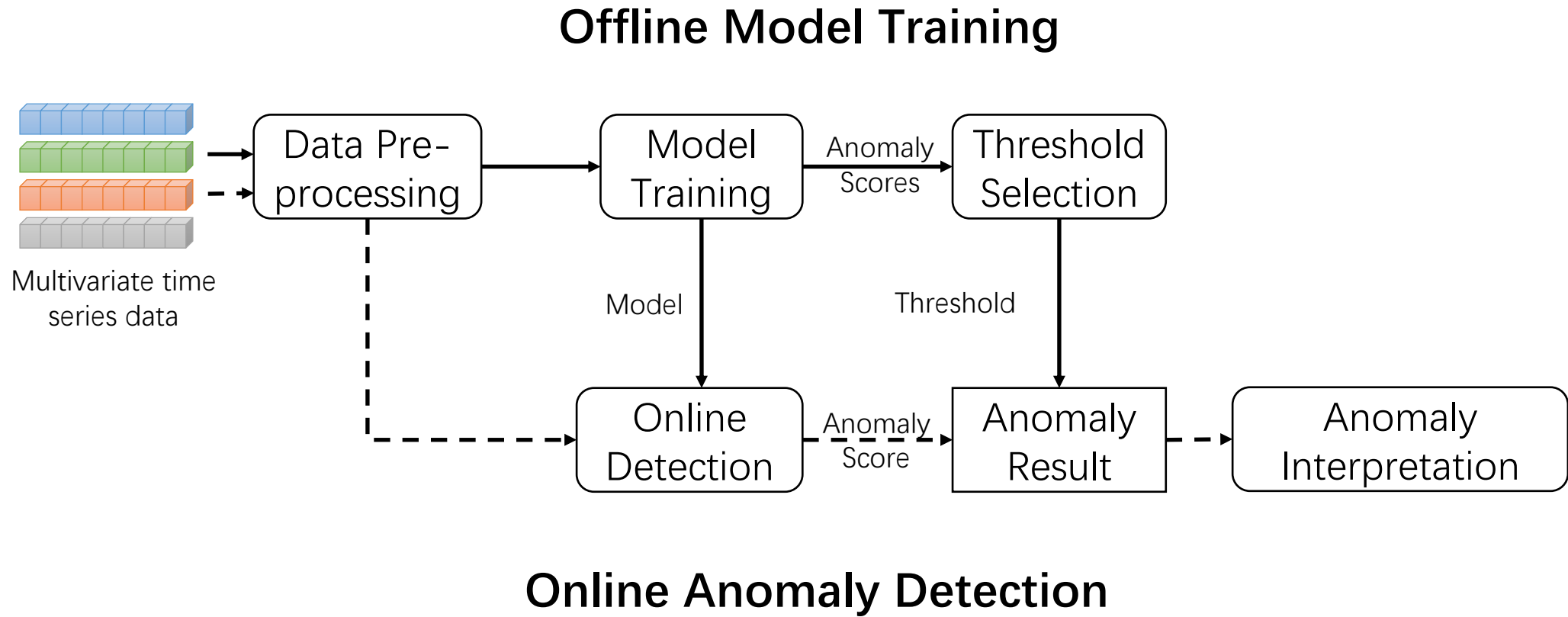

Model Architecture of OmniAnomaly

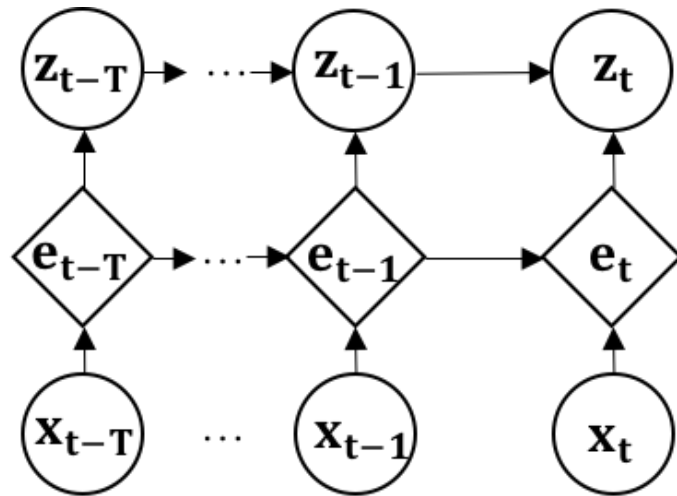

(a1) qnet

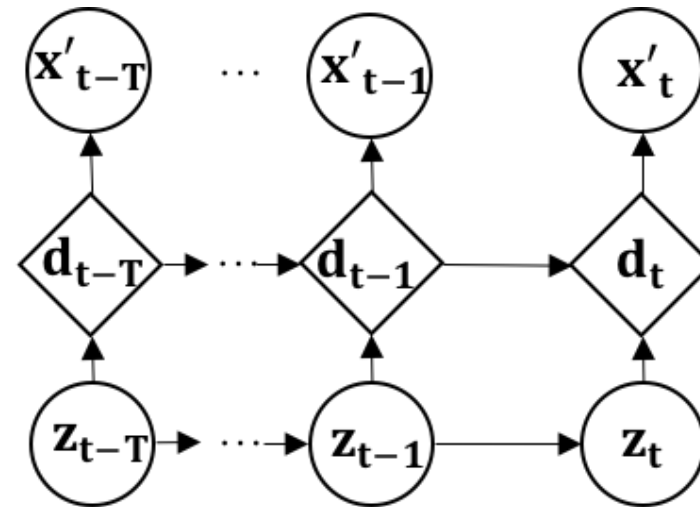

(a2) pnet

Model Architecture of OmniAnomaly

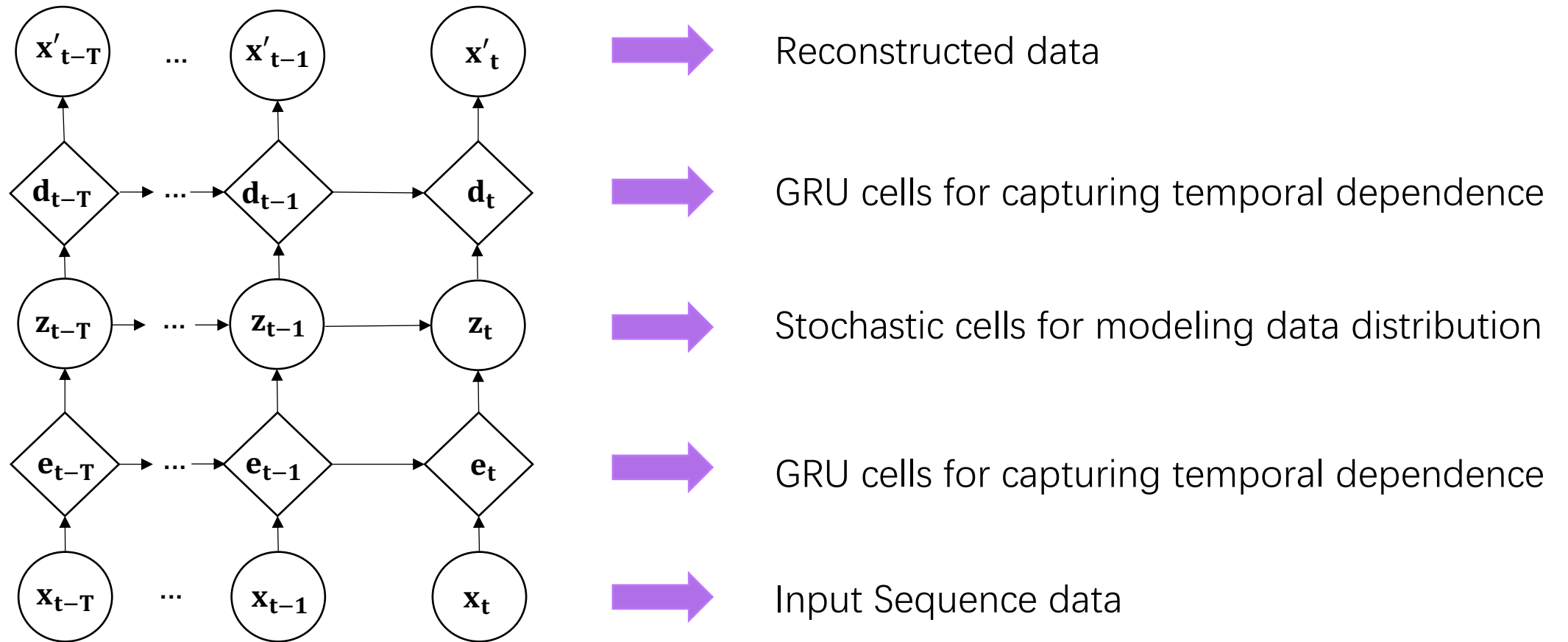

Core idea of OmniAnomaly

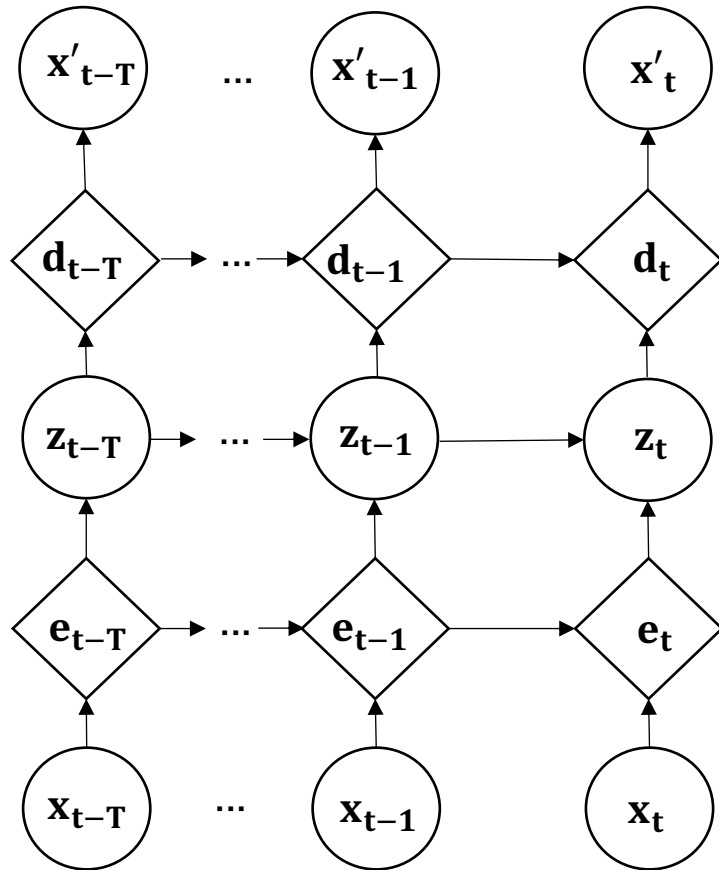

A good z_t can represent x_t well no matter x_t is anomalous or not.

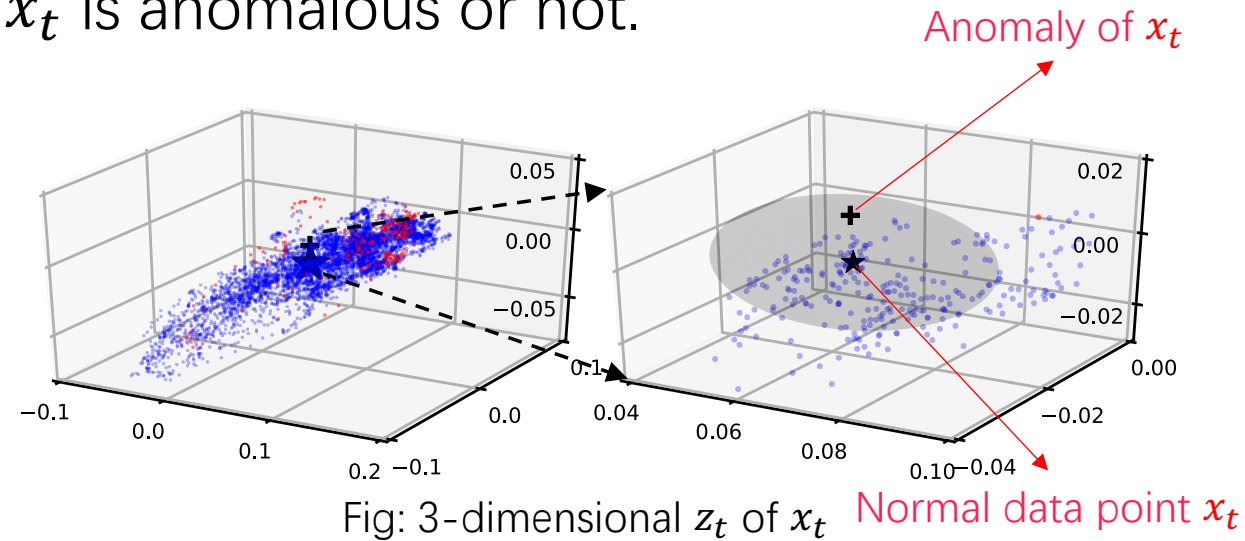

When x_t is anomalous, its z_t can still represent its normal pattern and x'_t will be normal too.

Anomaly detection of OmniAnomaly

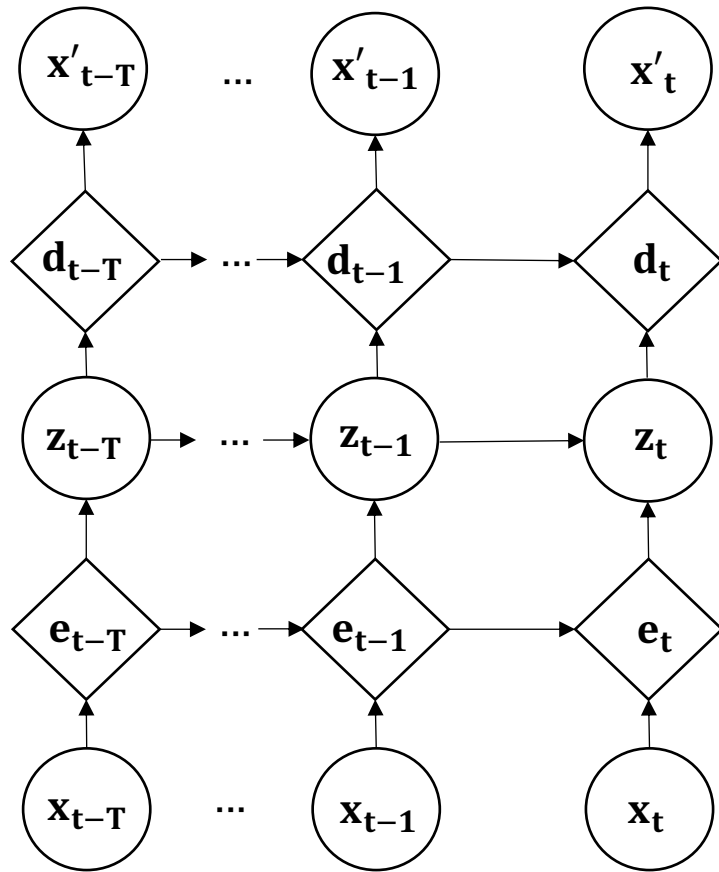

Anomaly Score $S_t =$
Reconstruction probability of x_t

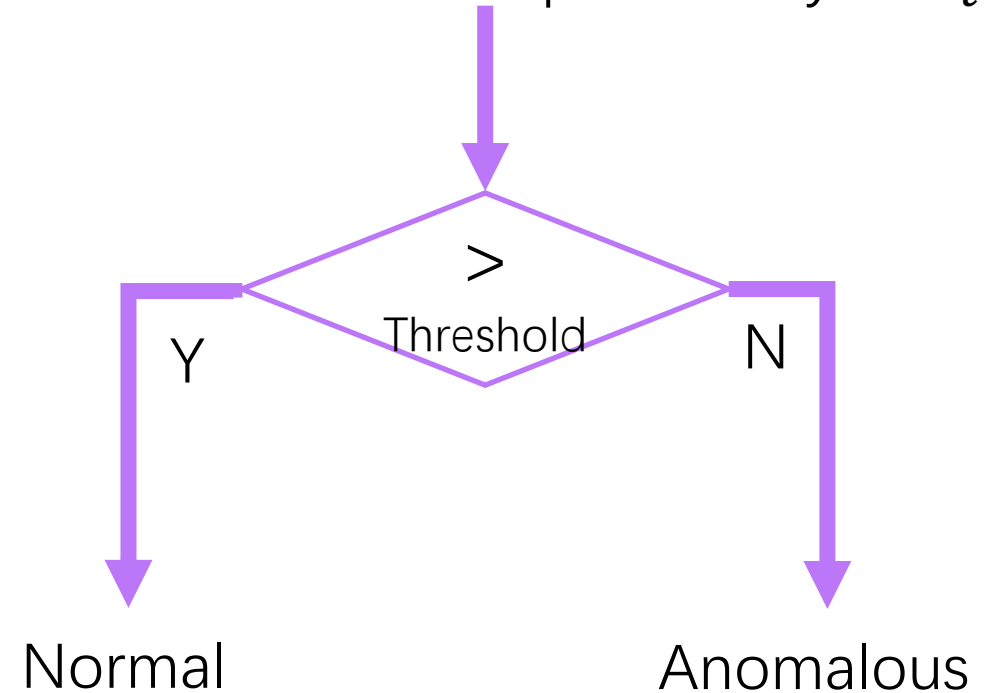

Anomaly detection of OmniAnomaly

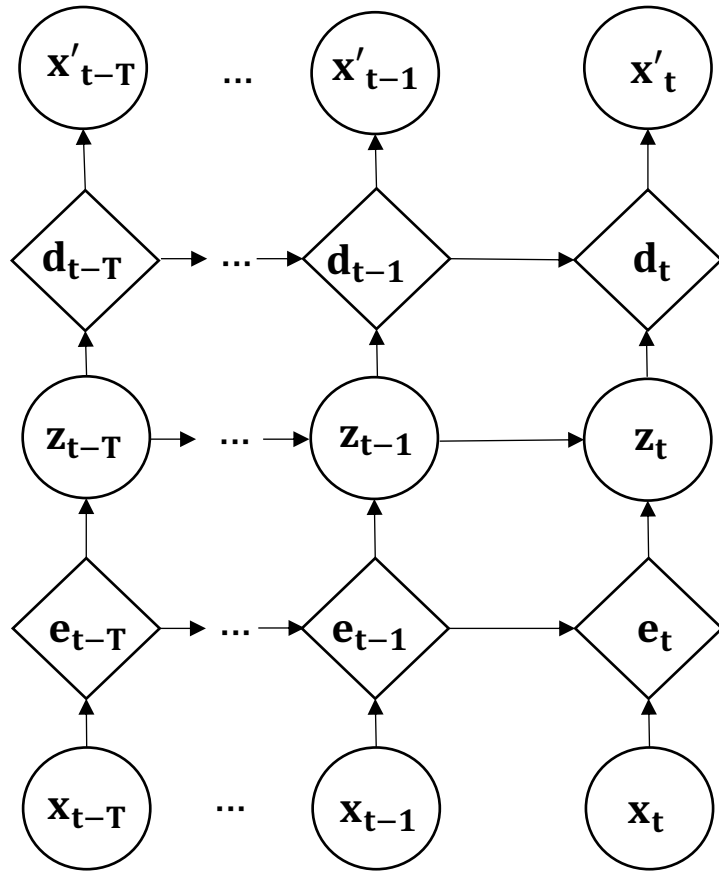

Anomaly Score $S_t =$
Reconstruction probability of x_t

$x_t = [x_t^1, x_t^2, \dots, x_t^M]$, M is the dimension

$$S_t = \sum_{i=1}^M S_t^i$$

Sort the $[S_t^1, S_t^2, \dots, S_t^M]$ in ascending order, and the Top K dimensions can interpret the anomaly.

Outline



Background



Algorithm



Evaluation



Conclusion

Datasets

DataSet name	Number of entities	Number of dimensions	Training set size	Testing set size	Anomaly ratio(%)
SMAP	55	25	135183	427617	13.13
MSL	27	55	58317	73729	10.72
SMD	28	38	708405	708420	4.16

F1-best of OmniAnomaly and baselines

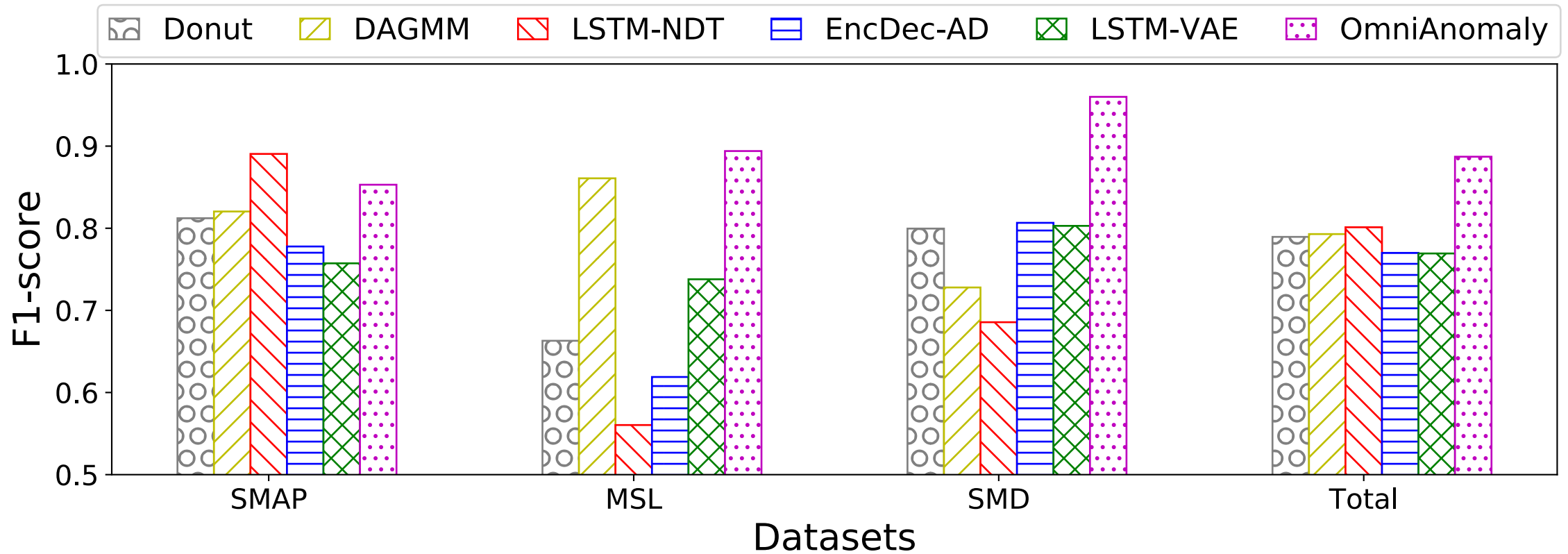

F1-best of OmniAnomaly and variants

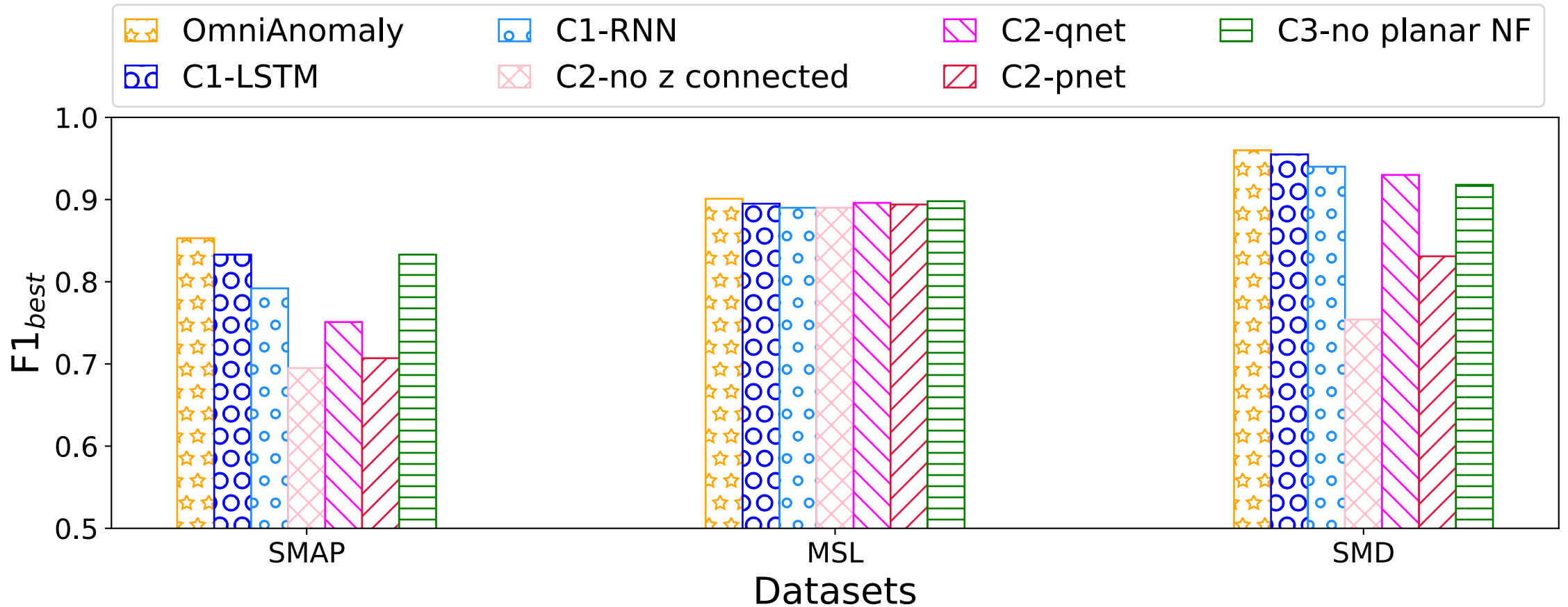

F1 obtained through POT vs. F1-best

Evaluation metrics for OmniAnomaly	SMAP	MSL	SMD
F1 obtained through POT	0.8434	0.8989	0.8857
F1-best	0.8535	0.9014	0.9620

F1-best of OmniAnomaly with different z dimension

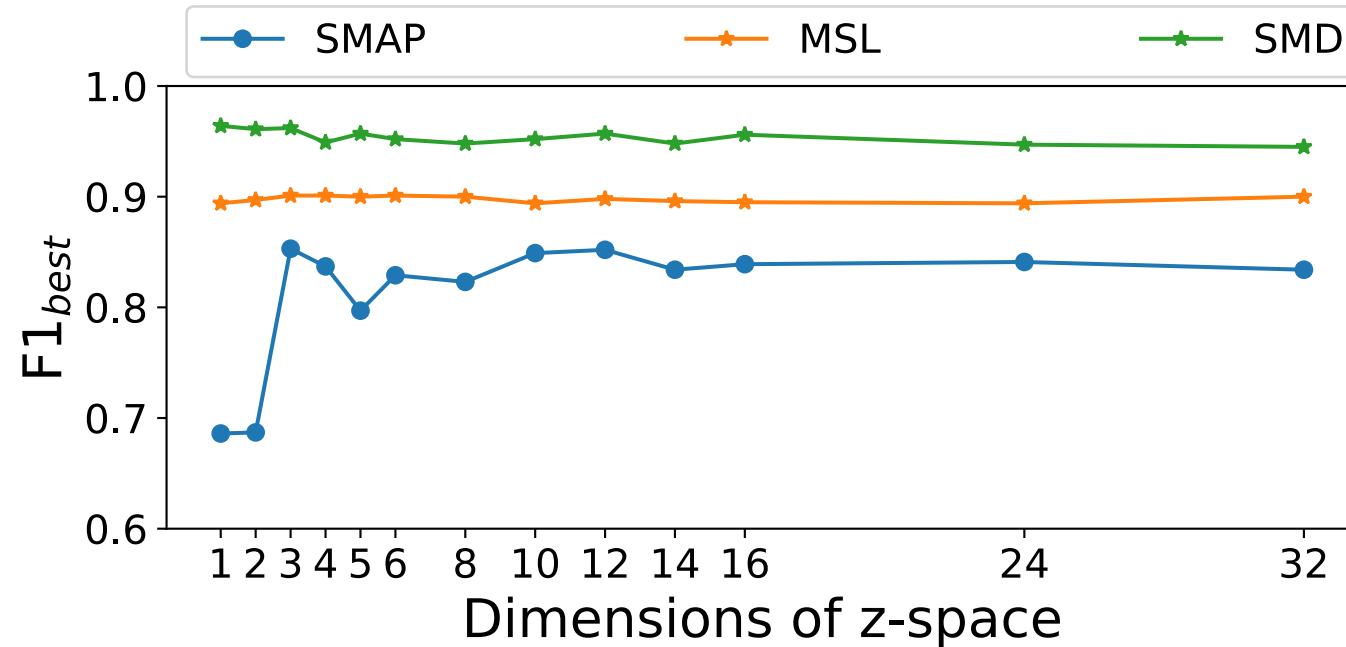

Outline



Background



Algorithm



Evaluation

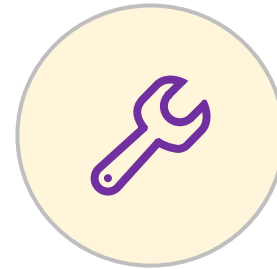

Conclusion

OmniAnomaly

- The first multivariate time series anomaly detection method that deal with explicit temporal dependence among stochastic variables
- The first anomaly interpretation approach for stochastic based multivariate time series anomaly detection algorithms
- Achieve an overall F1-score of 0.86 in three real world datasets.
- The interpretation accuracy is up to 0.89.

Lessons for time series data learning

- A combination of stochastic deep Bayesian model and deterministic RNN model is necessary
- The connection of stochastic variables is necessary and effective
- It is necessary to assume non-Gaussian distributions in z -space

Lessons for for multivariate time series anomaly detection

- Reconstruction-based models are more robust than prediction-based models
- It is critical to obtain robust latent representations which can accurately capture the normal patterns of time series
- Reconstruction-based stochastic approaches offer an opportunity to interpret the anomalies

Thanks

su-y16@mails.tsinghua.edu.cn



清華大學

Tsinghua University